

4

3

DWG NO 5210A015

SHEET

REV F

1

NEXT ASSEMBLY

REVISION HISTORY

REV	DESCRIPTION	ECN	DATE	BY	APPROVED
D	ADD POST & HEADER MOUNTING HOLES	4631	12/2/2004	AJW	
E	add channel lght=d.o.w.-.75	4887	10/6/2005	RJK	
F	UPDATE COMMENTS & VISION	5105	6/23/2006	RJP	

**SPECIFICATIONS:**

- GUARDIAN SIZE:** WIDTH: 2'-2" THRU 12'-6"  
HEIGHT: 2'-0" THRU 12'-0"
- CURTAIN MATERIAL:** STD. 50oz. ARMOR PLEAT, BLACK  
OPTIONAL VISION 21"  
OPTIONAL THERMOSHIELD BIB
- HEADER MATERIAL:** 8" x 11.5lbs C-CHANNEL
- ROLLER TUBE:** 4" DIA. STEEL TUBE
- CURTAIN GUIDES:** 14 GA. STEEL
- BARRIER BARS:** 3/4"OD X 1/8"W (DOW < 8'-6")  
1"OD X 1/8"W (DOW >= 8'-6")
- MOTOR:** 3 PHASE, 1HP MOTOR WITH BRAKE
- GEARBOX:** 15.33:1 WORM (12.33:1 OPTIONAL)
- UP/DOWN SPEED:** 30"/SEC UP/DOWN (36"/SEC OPTIONAL)
- LIMIT SWITCH:** TWO POSITION SWITCH WITH NO/NC CONTACTS

**MOTOR & LIMIT SWITCH CABLE:** 13' STANDARD

**OPTIONAL CONTROLS:**

**RELAY CONTROL BOX:** SIZE 12" x 10" x 6"  
INCLUDES OPEN, CLOSE AND STOP BUTTONS

PHONE #: (800)553-5560 (563)587-4401 FAX #: (563)589-2776

ITEM	QTY	PART NO.	DESCRIPTION
PARTS LIST / MATERIAL			

INCH TOLERANCES			DO NOT SCALE DRAWING	
OVER	UP TO	+ / -	MM-DD-YY	TITLE
0	0.125	0.005	DRAWN BY	AJW DATE 7/23/2003
0.125	0.25	0.010	CHECKED BY	DATE
0.25	1.25	0.020	APPROVED BY	DATE
1.25	5	0.030	INITIAL ECN	4197
5	15	0.040	DATE ISSUED	8/1/2003
15	40	0.060	REF	
40	80	0.100		
80	-	0.125		
ANGLES		+/- 1 DEG		
FINISH				

**FROMMELT® SAFETY PRODUCTS**

ARCHITECTURAL APPROVAL GUARDIAN WITH NON-CONTACT INTERLOCK OPTIO CATEGORY 4 CONTROLLER

SIZE	MODEL NUMBER	DWG NO	REV
B	1340	5210A015	F

©2003 RITE-HITE DOORS INC.

4

3

2

1

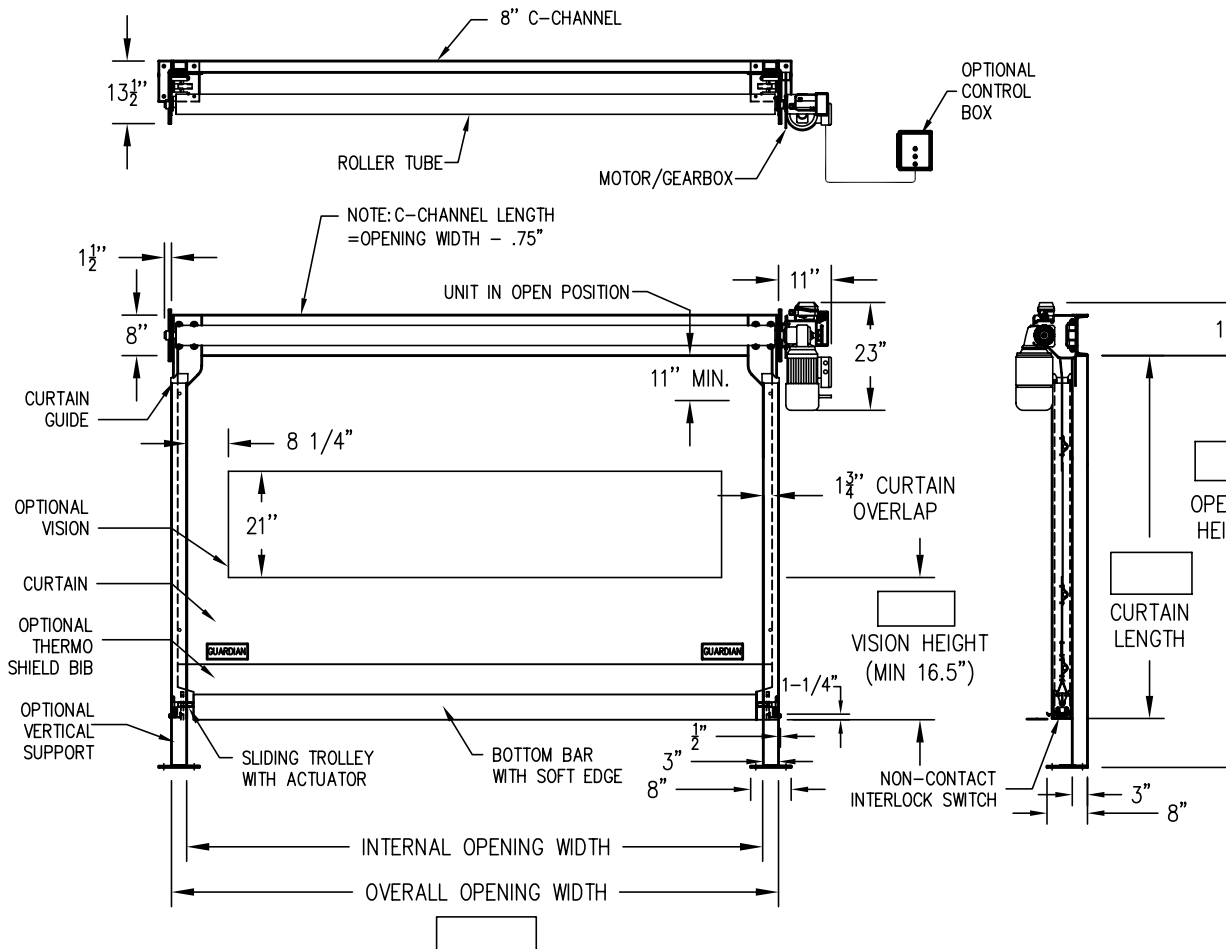

B

B

A

A