

4

3

DWG NO 5210A010

SHEET

REV E

1

NEXT ASSEMBLY

REVISION HISTORY

REV	DESCRIPTION	ECN	DATE	BY	APPROVED
D	ADD CHANNEL LNTH =D.O.W.-.75	4887	10/6/2005	RJK	
E	UPDATE COMMENTS & VISION	5105	6/23/2006	RJP	
C	ADD POST & HEADER MOUNTING HOLES	4631	12/2/2004	AJW	

**SPECIFICATIONS:**

- GUARDIAN SIZE:** WIDTH: 2'-2" THRU 12'-6"  
HEIGHT: 2'-0" THRU 12'-0"
- CURTAIN MATERIAL:** STD. 50oz. ARMOR PLEAT, BLACK  
OPTIONAL VISION 21"  
OPTIONAL THERMOSHIELD BIB
- HEADER MATERIAL:** 8" x 11.5lbs C-CHANNEL
- ROLLER TUBE:** 4" DIA. STEEL TUBE  
**CURTAIN GUIDES:** 14 GA. STEEL  
**BARRIER BARS:** 3/4"OD X 1/8"W (DOW < 8'-6")  
1"OD X 1/8"W (DOW >= 8'-6")
- MOTOR:** 3 PHASE, 1HP MOTOR WITH BRAKE  
**GEARBOX:** 15.33:1 WORM (12.33:1 OPTIONAL)  
**UP/DOWN SPEED:** 30"/SEC UP/DOWN (36"/SEC OPTIONAL)  
**LIMIT SWITCH:** TWO POSITION SWITCH WITH NO/NC CONTACTS
- MOTOR & LIMIT SWITCH CABLE:** 13' STANDARD

**OPTIONAL CONTROLS:**

**RELAY CONTROL BOX:** SIZE 12" x 10" x 6"  
INCLUDES OPEN, CLOSE & STOP BUTTONS

ITEM	QTY	PART NO.	DESCRIPTION
PARTS LIST / MATERIAL			

INCH TOLERANCES			DO NOT SCALE DRAWING	
OVER	UP TO	+ / -		
0	0.125	0.005		
0.125	0.25	0.010		
0.25	1.25	0.020		
1.25	5	0.030		
5	15	0.040		
15	40	0.060		
40	80	0.100		
80	-	0.125		
ANGLES +/- 1 DEG			INITIAL ECN 3999	
FINISH			DATE ISSUED 3/3/2003	
REF			MM-DD-YY	

**FROMMELT®**  
**SAFETY PRODUCTS**

TITLE ARCHITECTURAL APPROVAL GUARDIAN  
PHONE# (800)553-5560 (563)587-44  
FAX # (563)589-2776

SIZE B	MODEL NUMBER 1340	DWG NO 5210A010	REV E
SCALE 1/2"=1'	PART #	SHEET	

©2003 RITE-HITE DOORS INC.

4

3

2

1

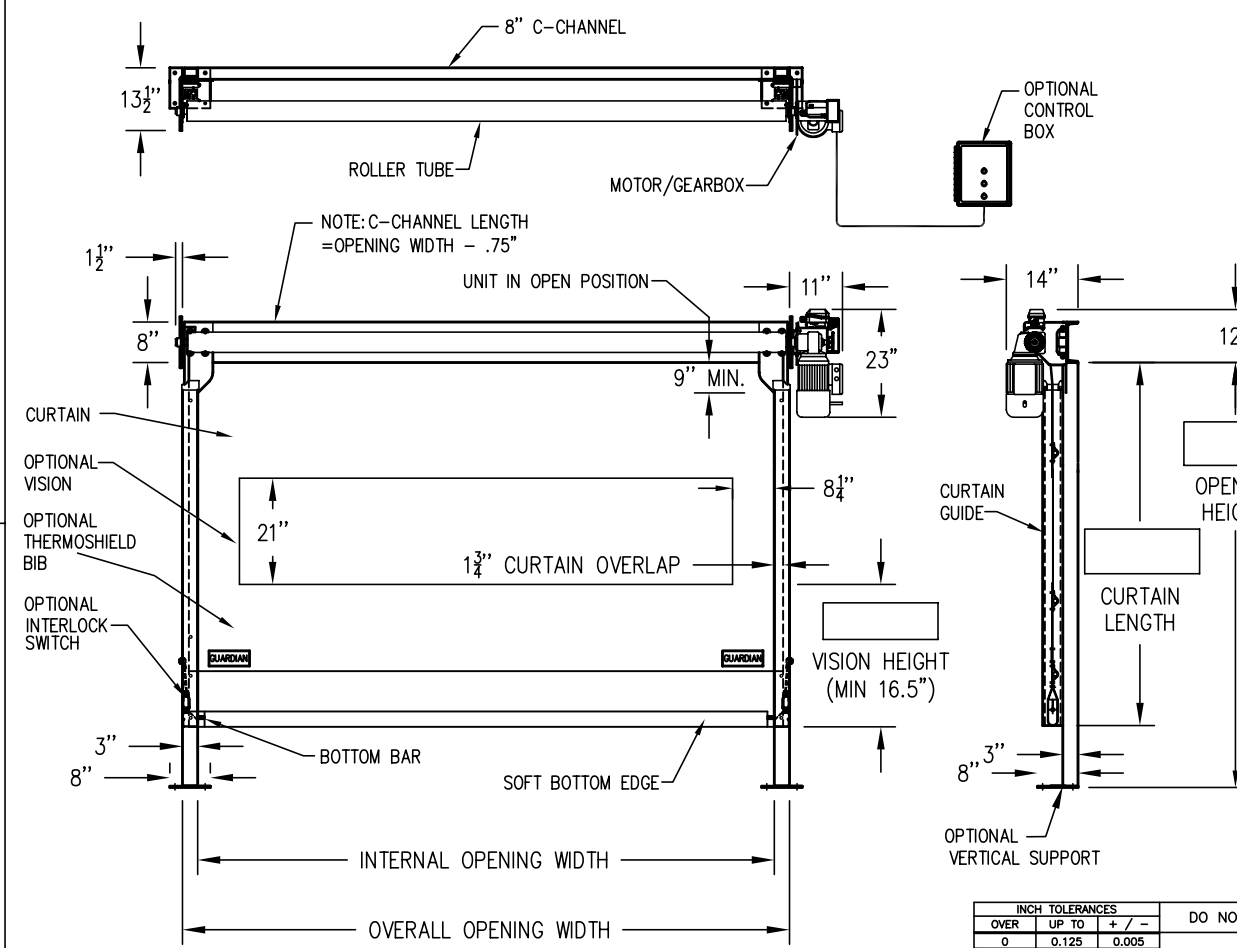

B

B

A

A