

The
Vital solution
handbook

≡ **JOKAB SAFETY** ≡

Vital

Approvals:



Application:

Safety solution for supervising different types of safety device in the same circuit

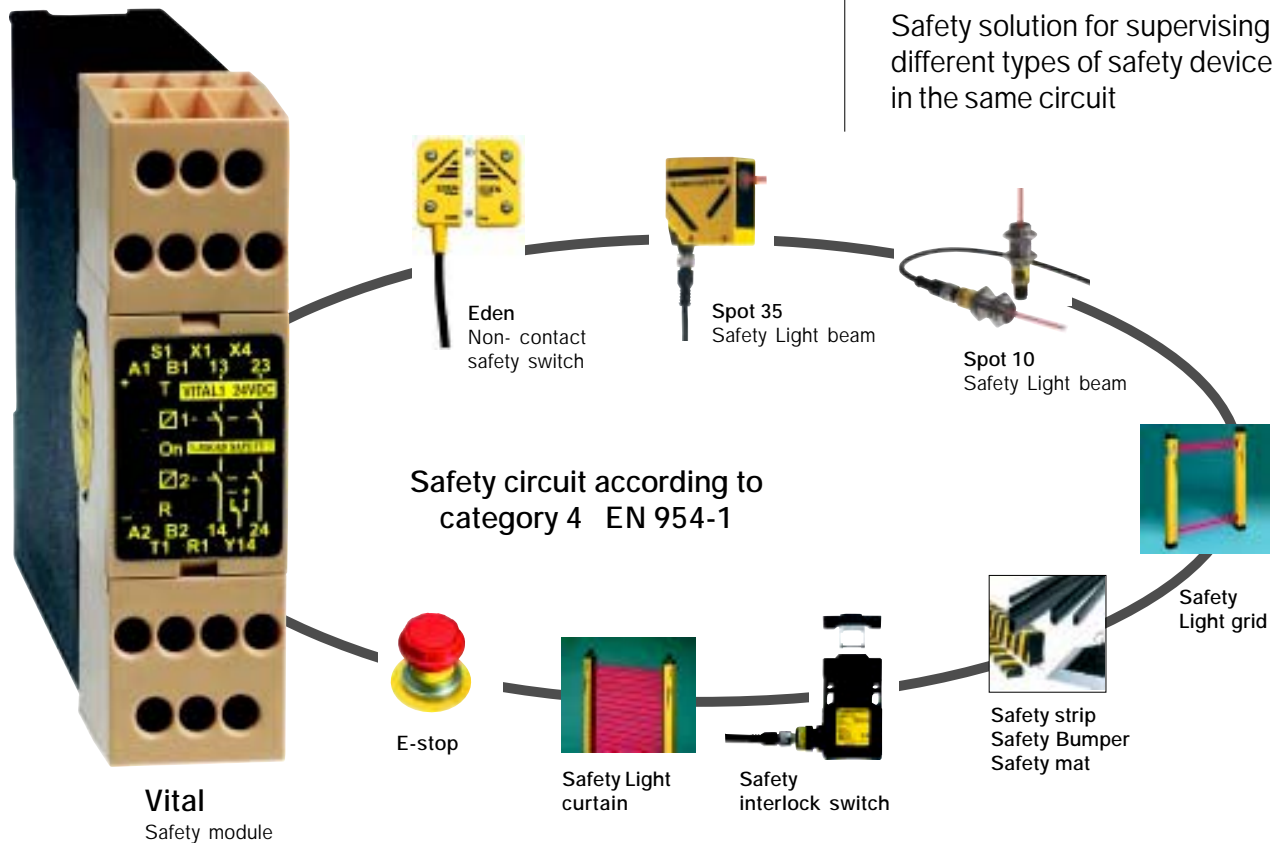

Vital
Safety module

Vital - the new generation of safety system

Vital is the heart of a new solution which makes it possible to install many different types of safety device connected in the same safety circuit and still achieve safety category 4 according to EN 954-1. Dynamic sensors can be connected directly to the Vital. Sensors with output contacts can be connected to the Vital via Tina devices.

Vital is a small (only 22.5 mm in width) electronic safety module which dynamically supervises many different types of safety device. It also has automatic or manual supervised reset, dual safety outputs, an information output for reset indication and status information for PLC's.

Detachable terminals make it easy to trouble shoot and to change a module.

Features:

Safety category 4, dynamic safety circuit

Width 22.5 mm

Long cable lengths

Manual supervised or automatic reset

Two NO safety outputs

Quick release connection blocks

LED indication of power on, dynamic signals and output status

Relay status information output

Connection of units and cable lengths to Vital 1

Three connection alternatives

According to Category 4 (EN-954-1) connection of sensors/adaptor units in the Vital safety circuit must be made as per the following connection examples (see drawing HH3400A below).

Example 1

Use separate connection cables from each sensor/adaptor unit to the Vital safety module. Interconnections to be made via suitable terminations in the control cabinet.

Example 2

Use Tina4A/Tina8A connector blocks to simplify connection of externally mounted sensors/adaptor units. Only Tina4A/Tina8A connector blocks must be used. Use of any other connector blocks will not meet the safety circuit requirements.

Example 3

Use M12-3A and M12-3B 'Y' connectors to connect sensors in series.

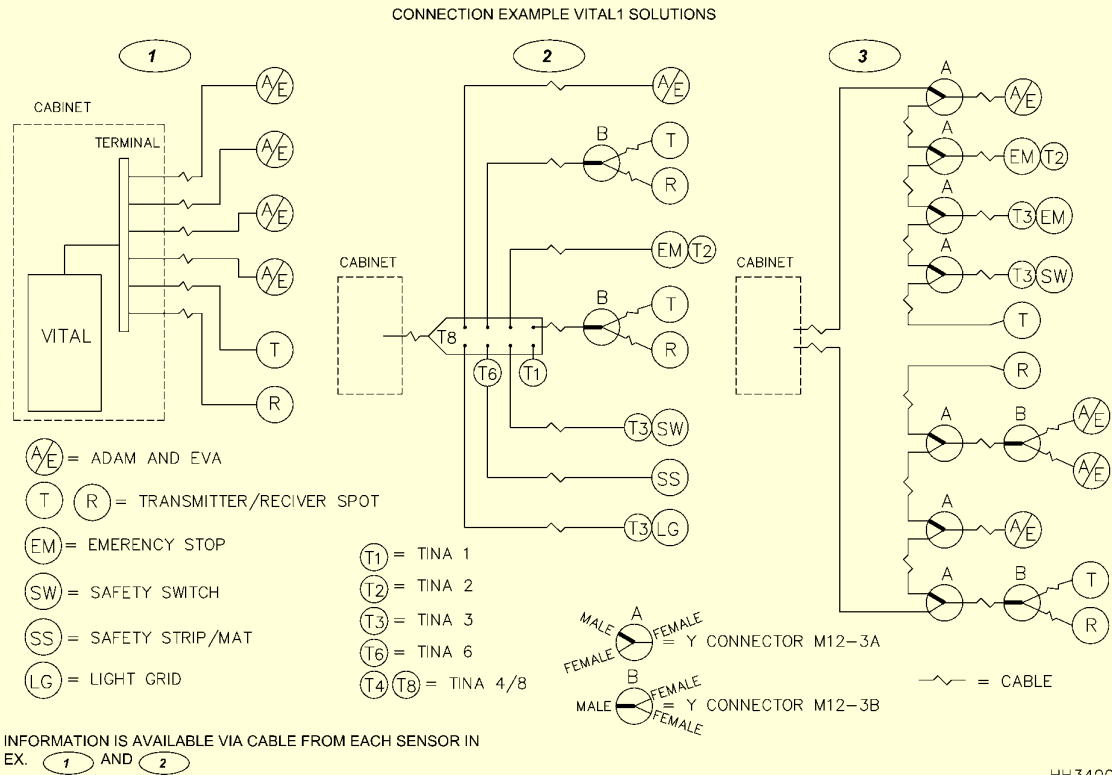

Cable lengths and number of sensor/adaptor units for the three connection examples.

In order to determine the number of sensor/adaptor units that can be connected to a Vital 1 unit it must be remembered that 1(one) Spot T/R is equivalent to 5(five) Eden or Tina units. Units in parallel are equal to one unit. The following examples provide **guidance** as to possible configurations and cable lengths using suitable cables.

Example 1

Up to 1000 Metres (0.75mm² or 0.34mm² conductors) in total can be connected to the sensors/units in this example. The connection is equivalent to 9 Eden or Tina units.

A maximum of 30 Eden or Tina units can be connected to the Vital 1 unit on a maximum cable length of 500 Metres (0.75mm² conductors) or 300 Metres (0.34mm² conductors).

Example 2

Up to 600 Metres (0.75mm² conductors) to Tina 8A and 10 Metre cables type M12-C1012 (0.34mm²) to each sensor/unit connected to the Tina 8A. This connection example is equivalent to 17 Eden or Tina units.

A maximum of 3 Tina 8A units, equivalent to 27 Eden/Tina units (= 3 x 8 connected to Tina 8A + 3 Tina 8A) can be connected to one Vital 1 with a total cable length of 600 Metres (0.75mm²). Up to 6 Tina 4A units can be connected to one Vital 1 (equivalent to 30 Eden/Tina units) with a total cable length of 600 Metres (0.75mm²) to Tina 4A.

Example 3

Either 2 x 500 Metre cables (0.75mm²) from the control cabinet and 10 Metre cables (0.34mm²) to each sensor/unit or 2 x 10 Metre cables (0.75mm²) from the control cabinet and 200 Metre cables (0.75mm²) to each sensor/unit. The connection is equivalent to 16 Eden or Tina units.

A Total of 30 Eden/Tina units can be connected using a maximum cable length of 1000 Metres (0.75mm²) or 400 Metres (0.34mm²). If power supply is only made from one direction (from one end of the network) the total cable length is reduced to approx 300 Metres (0.75mm²) and 100 Metres (0.34mm²).

Reset connections - Vital1

Manual supervised reset

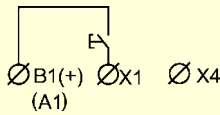

The manual supervised reset contact connected to input X1 must be closed and opened in order to activate the relay outputs.

Automatic reset

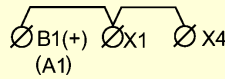

Automatic reset is selected when B1(A1), X1 and X4 are connected. The relay outputs are then activated at the same time as the inputs.

Testing external contactor status

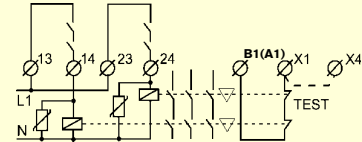

Contactors, relays and valves can be supervised by connecting 'test' contacts between B1(A1) and X1. Both manual supervised and automatic reset can be used.

Output connection - Vital1

Relay outputs

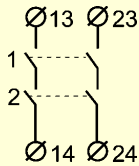

The Vital 1 has two (2 NO) safety outputs. In order to protect the output contacts it is recommended that loads (inductive) are suppressed by fitting correctly chosen VDR's, diodes etc. Diodes are the best arc suppressors, but will increase the switch off time of the load.

Information outputs

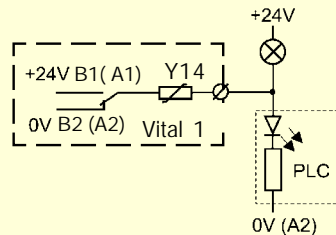

The Vital 1 has a single changeover contact information relay output. The relay output Y14 is connected internally to 0V and 24V in the following way:

- Y14 is internally closed to 0V B2 (A2) when the Vital 1 is not reset.

- Y14 is internally closed to 24V B1(A1) when the Vital 1 is reset.

Connection of S1

Even numbers of sensors (Eden, Spot, Tina) requires a connection between B1(A1) and S1.

S1 is not to be connected for odd numbers of sensors.

See connection examples below fig. A and B.

Connection of safety devices to Vital1

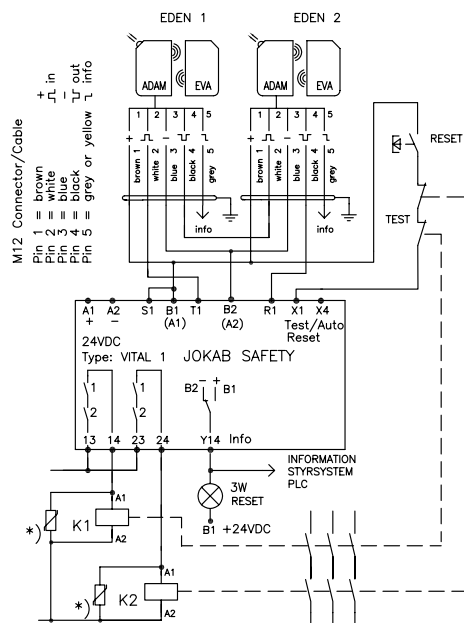

A) EDEN med manuell återställning samt övervakning av yttre kontaktorer/reläer
EDEN with manual reset and monitoring of external contactors/relays

*OBS: Använd alltid transient skydd Lex. VDR!
*NOTE: Always use transient suppressors, e.g. VDR's!

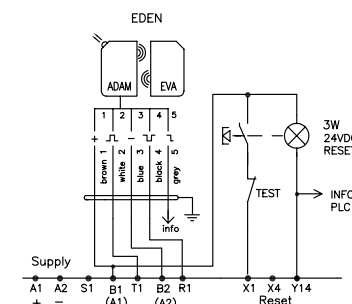

B) EDEN med manuell återställning
EDEN with manual reset

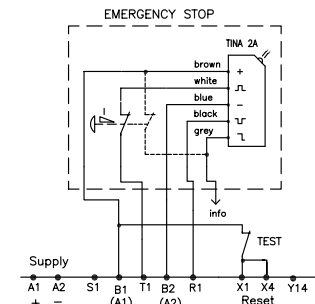

C) Nödstopp med TINA2A och aut. återställning.
Emergency stop with TINA2A and autom. reset.

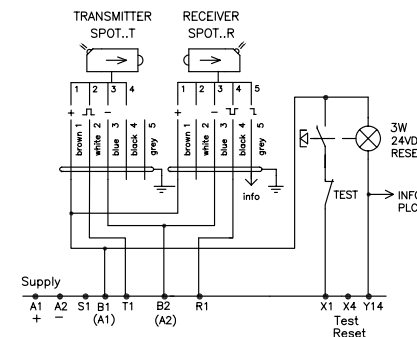

D) Ljusbom SPOT med manuell återställning
Safety Lightbeam SPOT with manual reset

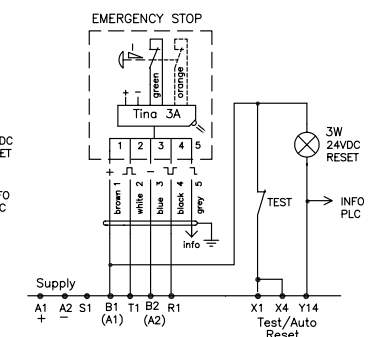

E) Nödstopp med TINA3A och aut. återställning.
Emergency stop with TINA3A and autom. reset.

Technical data – Vital1

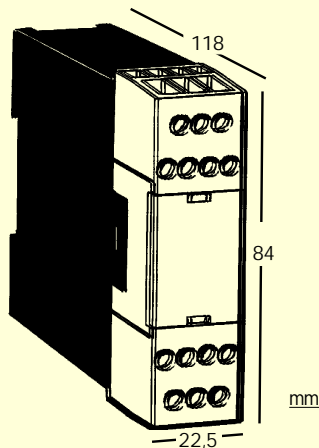

Manufacturer JOKAB SAFETY AB, Sweden
Ordering data Vital 1
Safety category (according to EN 954-1) 4

Colour Black and beige
Weight 220 g

Power supply
 Vital, A1-A2 24 VDC +/- 15%
 From Vital to sensors/units, B1-B2 24 VDC +/- 15%

Power consumption
 DC supply, nominal voltage (without load) 3 W

Dynamic safety circuit
 T 1 Output signal
 R 1 Input signal

Reset input X1
 Supply for reset input +24VDC
 Reset current 30 mA max. (inrush current 300 mA during contact closure)
 Minimum contact closure time for reset 80 ms

Connection of S1
 Even numbers of sensors (Eden + Spot T/R + Tina) require a connection between B1 (A1) and S1. S1 is not connected for odd numbers of sensors.

Number of sensors
 Max. number of Eden/Tina to Vital 1 30 pcs
 Total max. cable length to Eden/Tina 1000 m
 Max. number of Spot T/R to Vital 6 pairs
 Total max. cable length to Spot T/R 600 m

The above limits vary depending on cable size and application. See connection example in section: Connection of units and cable lengths to Vital 1.

Response time
 At Power on < 85 ms
 When activating (input-output) < 45 ms
 When deactivating (input-output) < 25 ms
 At Power loss < 35 ms

Relay outputs
 NO 2
 Max switching capacity, resistive load 6A/250 VAC/1500 VA/150W
 Minimum load 10 mA/10V
 Contact material AgCdO
 Mechanical life >10⁷ operations

Relay information output (changeover contact)
 Y14 -(0V) Indicates Vital is not reset
 +(24V) Indicates Vital is reset
 Max. permissible load on Y14 200 mA
 (Internal automatic fuse)

LED indication
 On ● Fixed light: supply voltage OK,
 Flashing light: under-voltage or overload.
 T ● R ● T - Signal out OK. R - Signal in OK.
 ☒ ● 1 ☒ ● 2 Indicates that the output relays have been activated

Mounting
 DIN rail 35 mm DIN rail
 Operating temperature range -10°C to + 55°C

Connection blocks (detachable)
 Max screw torque 1 Nm
 Max connection area:
 Solid conductors 1x4mm²/2x1,5mm²/12AWG
 Conductor with socket contact 1x2,5mm²/2x1mm²
 Air and creep distance 4kV/2 DIN VDE 0110

Protection class
 Enclosure IP 40 IEC 60529
 Connection blocks IP 20 IEC 60529

Non-contact safety sensor Eden



A non-contact safety sensor for the highest safety level

Eden - Adam and Eva is a non-contact switch for use on interlocked gates, hatches etc. A coded signal is transmitted from the control device Vital via Adam to Eva which modifies the signal and sends it back again. The maximum sensing distance between Adam and Eva is currently 10 mm.

Up to 30 Edens can be connected in series and still achieve the same safety level in the safety circuit. It is also possible to connect safety light beams and E-stops in the same safety circuit.

Adam is available with cable lengths up to 10 m and with M12 connectors. The LED on Adam provides indication of three different conditions, contact/non contact between Adam and Eva and safety status. The same information is also available via the Adam connection cable. Eden is available for harsh environments, Adam E and Eva E.

Approvals:



Safety sensor for:

- Doors and hatches
- Position control
- Sector detection
- Slot detection

Features:

- Safety category 4 according to EN 954-1 together with Vital
- Non-contact detection
- Up to 30 sensors connected in series at safety category 4
- Versatile mounting, 360° detection
- Protection class IP67
- Signal will penetrate through non-metallic materials (wood, plastic, etc)
- Safety light beams, E-stops and Eden can be connected in the same safety circuit together with Vital meeting safety category 4 (EN 954-1).
- LED indication on sensor and status information via the connector cable

Detection distance - Eden

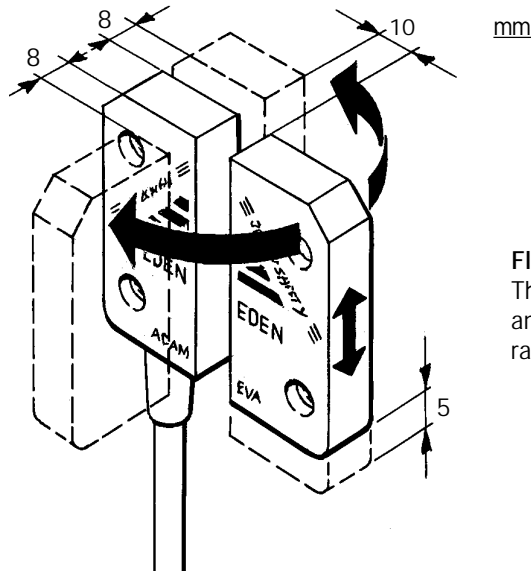

Flexible mounting

The ability to operate at distances of up to 10mm and at different detection directions allows a wide range of mounting possibilities.

Application examples - Eden

Eden to detect position

Adam and Eva has contact only if they are within 10 mm from each other.

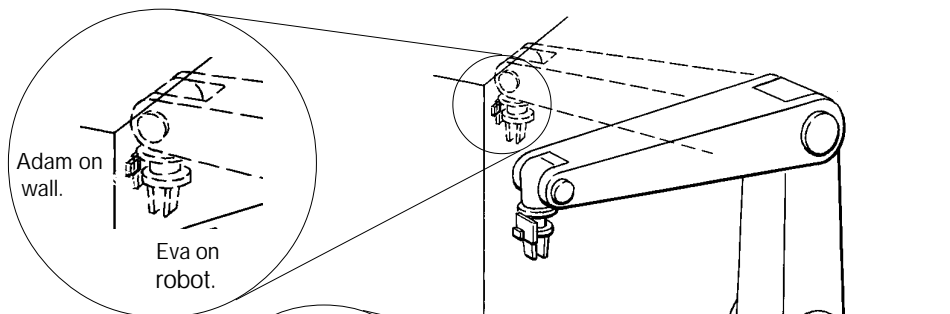

Eden used for sector detection

Metal stops the signal between Adam and Eva. Additional Eden sensor(s) can be mounted to detect metal plate(s) in place.

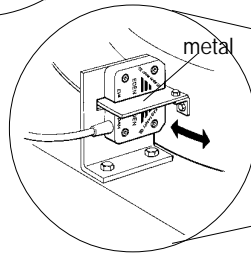

Eden used for detection of position of saw guard

Wood, plastic and other non-metallic material lets the signal pass between Adam and Eva.

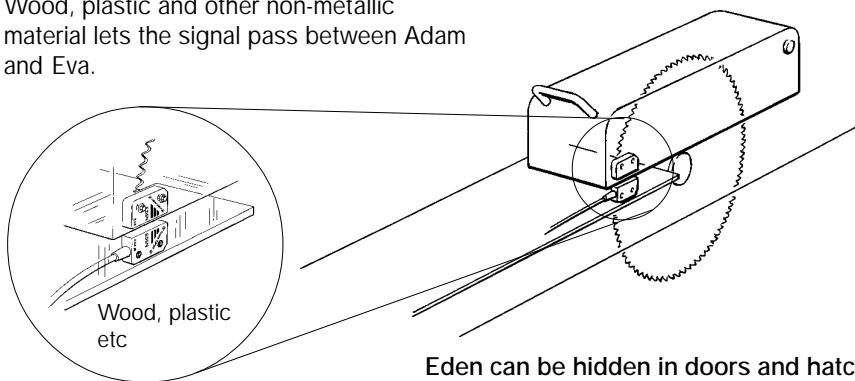

Eden can be hidden in doors and hatches
Non-metallic door material between Adam and Eva allows signal through.

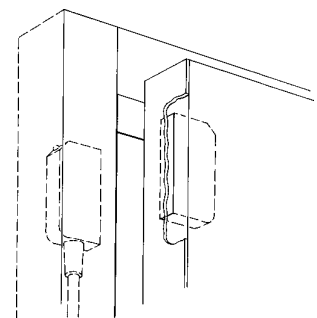

Mounting - Eden

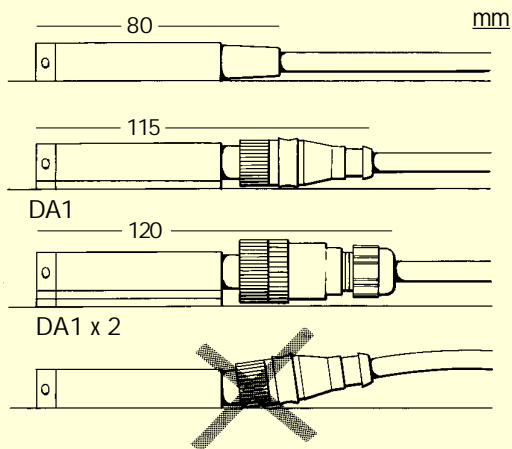

Mounting Adam with integral cable.

Mounting with one protection plate (DA1) for Adam M12 using prewired moulded M12 connector.

Mounting with two protection plates (DA1) for Adam M12 using M12 connector with glanded cable.

Wrong mounting without protection plate may cause permanent damage to sensor.

Notes:

Four protection plates are supplied with Adam M12. To protect Adam and Eva protection plate (DA1) can be used on both sides.

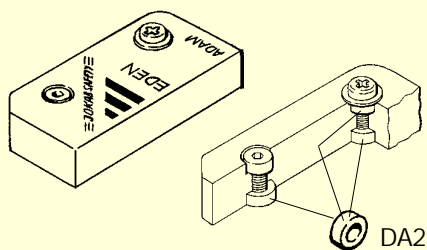

DA2 mounting

The DA2 mounting spacer must be used in order to physically protect Eden from damage. Four spacers are provided with each Adam and Eva.

Connection of Eden to Vital 1

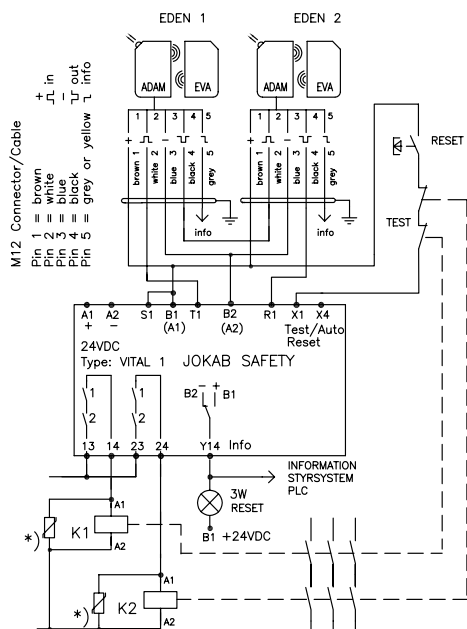

A) EDEN med manuell återställning samt övervakning av yttre kontaktorer/reläer
EDEN with manual reset and monitoring of external contactors/relays

*)OBS: Använd alltid transientkydd t.ex. VDR!
*)NOTE: Always use transient suppressors, e.g. VDR's!

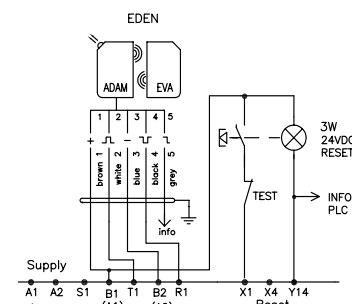

B) EDEN med manuell återställning
EDEN with manual reset

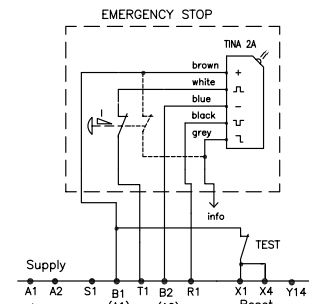

C) Nödstopp med TINA2A och aut. återställning.
Emergency stop with TINA2A and autom. reset.

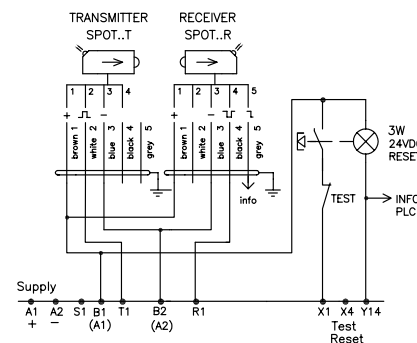

D) Ljusbom SPOT med manuell återställning
Safety Lightbeam SPOT with manual reset

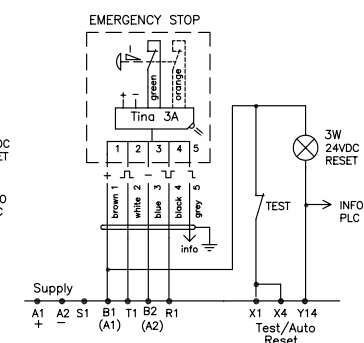

E) Nödstopp med TINA3A och aut. återställning.
Emergency stop with TINA3A and autom. reset.

Technical data – Eden

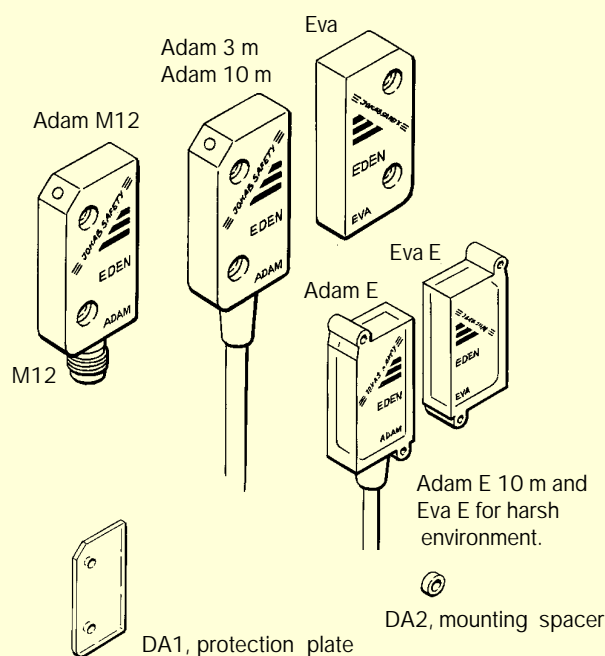

Dimensions for Eden and Eden E

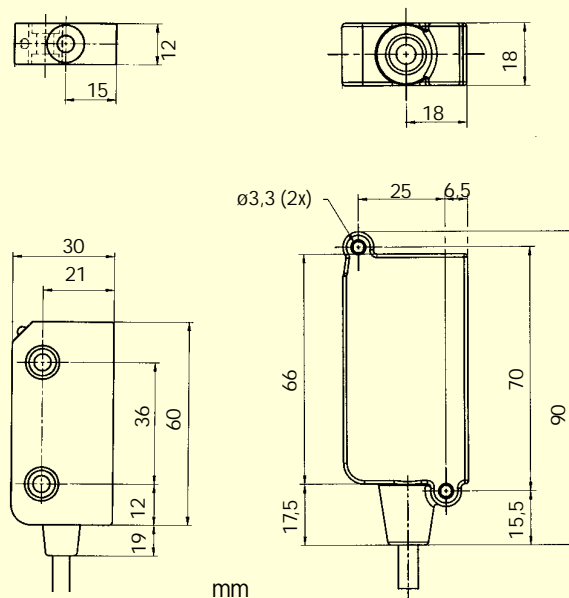

Manufacturer Jakob Safety AB, Sweden
Ordering data Adam M12, Adam 3 m
Adam 10 m, Adam E10 m,
Eva and Eva E

Material Macromelt (Based on polyamid)
Eden E is also covered by polypropen.

Safety category together with Vital
(according to 954-1) 4

Chemical resistance
Macromelt: Cutting oils, vegetable and animal oils,
hydrogen peroxide, diluted acids and bases: good
Alcohol and strong acids: not recommended
PP (Eden E): Cutting oils, vegetable and animal oils,
hydrogen peroxide, diluted acids and bases, alcohols: good
Strong oxidating acids: not recommended

Colour Yellow and black
Weight Adam M12: 30 g
Adam 3 m: 220 g incl. cable
Adam 10 m: 650 g incl. cable
Adam E10 m: 660 g incl. cable
Eva: 26 g
Eva E: 36 g

LED on Adam
Green: Eva within range, safety circuit closed (door closed)
Flashing: Eva within range, earlier safety circuit open
(door closed)
Red: Eva out of range, safety circuit open (door open)

Power supply 17 - 27 VDC, ripple max 10%

Cable 3 or 10 m, \varnothing 5.7mm, black, PVC
5 x 0.34mm² + screen, UL 2464

Power consumption Adam: without info output 45 mA
with info output max 60 mA

Connector M12: 5-pin male contact

Max cable length see Vital technical data

Ambient temperature -25°C to + 55°C (operation)
-30°C to +70°C (stock)

Connections
Brown (1) +24 VDC
White (2) Dynamic signal in
Blue (3) 0 VDC
Black (4) Dynamic signal out
Grey (5) Info output, see below

Protection class IP67

Mounting 4 pcs M4 screws + DA2 spacer
max torque 0.5 Nm
Screws should be locked with loctite or similar.

24 VDC when LED is green or flashing
(tolerance -2 VDC)
0 VDC when LED is red
(tolerance +2 VDC)

Detection distance max 8-10 mm
Hysteresis approx. 1 mm

Metal may have influence on detection distance. This can
be prevented by protection plates, DA1.

Warning: Incorrect connection may cause permanent
damage to Adam devices.

Minimum distance between Eden pairs 50 mm
Life >10⁷ cycles



DET NORSKE VERITAS

CERTIFICATE OF CONFORMITY

Application of AFS 1994:48
(Council Directive 98/37/EC of 22 June 1998 on Machinery)

CERTIFICATE NO. 01-MAL-CM-0125

with enclosure no 1.
This is to certify that the

Safety concept

with the type designation
Vital solution

manufactured by
Jokab Safety AB

in
Sweden

is found to comply with the Essential Health and Safety Requirements in Annex 1 of
AFS 1994:48 and complies with Category 4 in standard EN 954-1:1996.

Conformity assessment according to 8-10 §§ in AFS 1994:48 is documented in
Report no. 01-MAL-CM-0125

Stockholm, 15 August 2001
DET NORSKE VERITAS INSPECTION AB
Product and Personnel Certification

Adela Hirschberg
Service Responsible Machinery

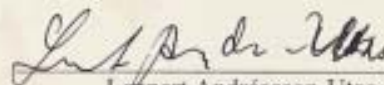

This Certificate is valid until
15 August 2006

Lennart Andréasson-Utas
Certification Engineer

Notice: Any significant changes in design or construction of the product or amendments to the AFS 1994:48 (Directive 98/37/EC) or standards referenced above may render this certificate invalid. The product liability rests with the manufacturer or his representative in accordance with the AFS 1994:48.



Enclosure no 1 to certificate no 01-MAL-CM-0125

The contents of the Vital solution are the following units:

Safety unit: Vital 1

Lightbeam: Spot 10 T/R and Spot 35 T/R

Non contact switch: Eden (Adam and Eva)

Connection support: Tina 1-8, several adaptation/connection details for the connection of the units above and also emergency buttons, limit switches, tape switches and pressure sensitive flooring.

The following initiators/units are dynamic:
lightbeam Spot, non contact switch Eden and connection support Tina.

Connection with dynamic initiators (also several in series) complies with Category 4.

Det Norske Veritas Inspection AB
Product and Personnel Certification
Malmö 01.08.30

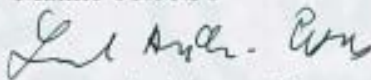
Lennart Andréasson-Utas