

REVISION HISTORY				
REV.	DATE	NOTE	ECN	BY
-01	1/14/2011			
A	1/27/2011	1345 CONVERSION FROM AUTOCAD		

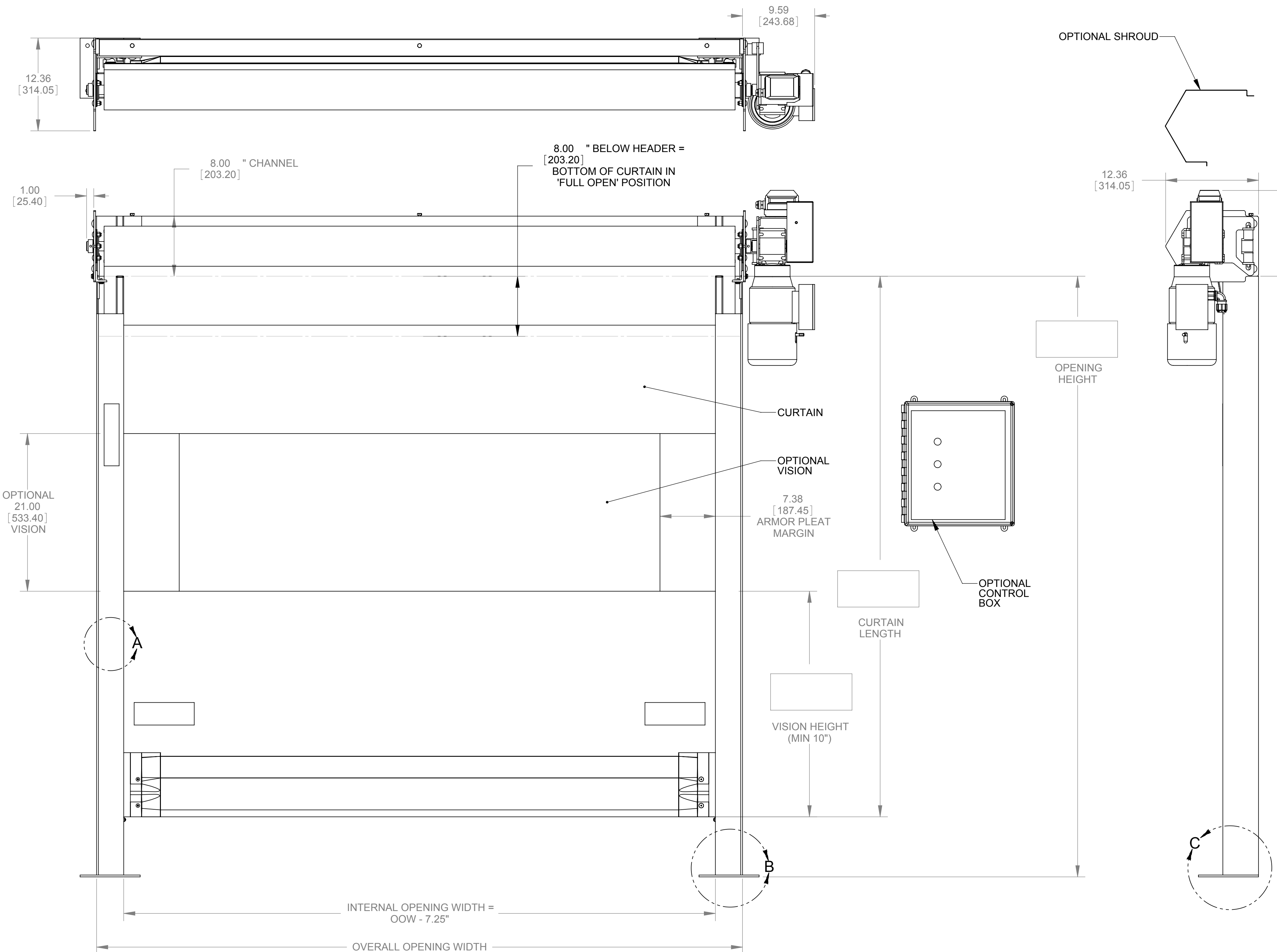

SPECIFICATIONS:

GUARDIAN SIZE: WIDTH: 2'-2" THRU 16'-0"
 HEIGHT: 2'-0" THRU 16'-0"
 CURTAIN MATERIAL: STD. 50oz. ARMOR PLEAT, BLACK
 OPTIONAL VISION 21"

HEADER MATERIAL: 8" x 11.5lbs C-CHANNEL
 ROLLER TUBE: 4" DIA. 11 GA. STEEL TUBE
 SIDEFAMES: 11 GA. STEEL

MOTOR: 3 PHASE, 1HP MOTOR WITH BRAKE
 GEARBOX: 10:1 WORM (7.5:1 OPTIONAL)
 UP/DOWN SPEED: 40"/SEC UP/DOWN (55"/SEC OPTIONAL)
 LIMIT SWITCH: TWO POSITION SWITCH WITH NO/NC CONTACTS
 MOTOR & LIMIT SWITCH CABLE: 13' STANDARD (OPENING HT <= 12'-0")
 20' STANDARD (OPENING HT > 12'-0")
 50' OPTIONAL

OPTIONAL CONTROLS:

RELAY CONTROL BOX: SIZE 16" X 14" X 8.5"
 INCLUDES OPEN, CLOSE AND STOP BUTTONS

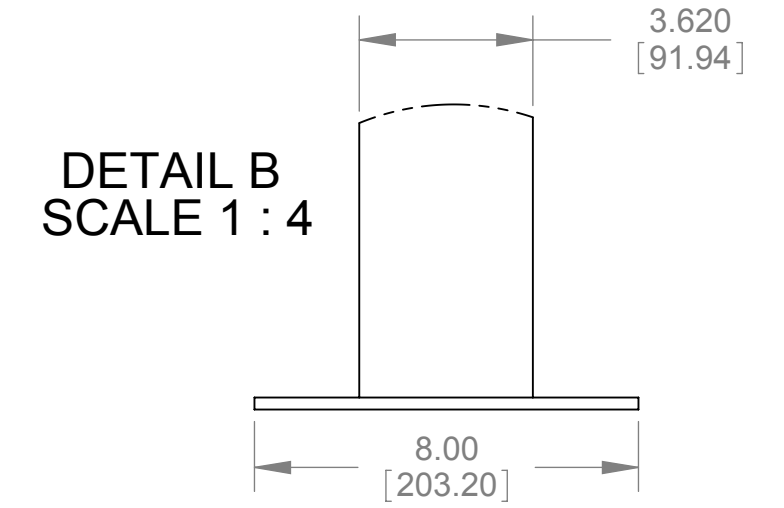
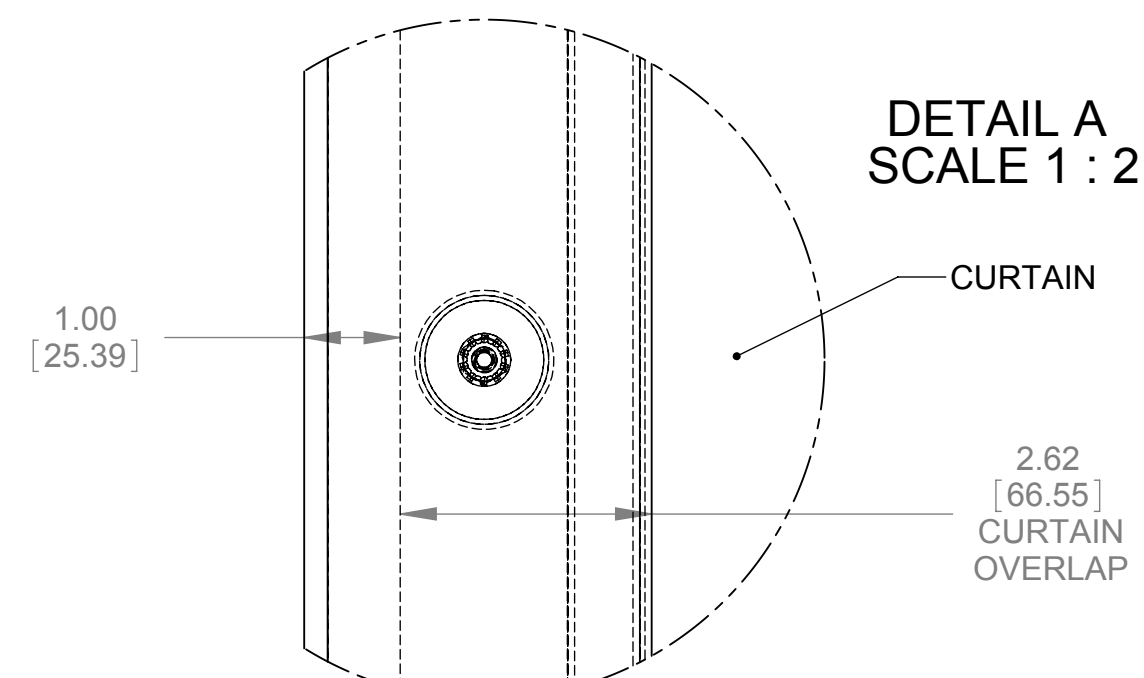
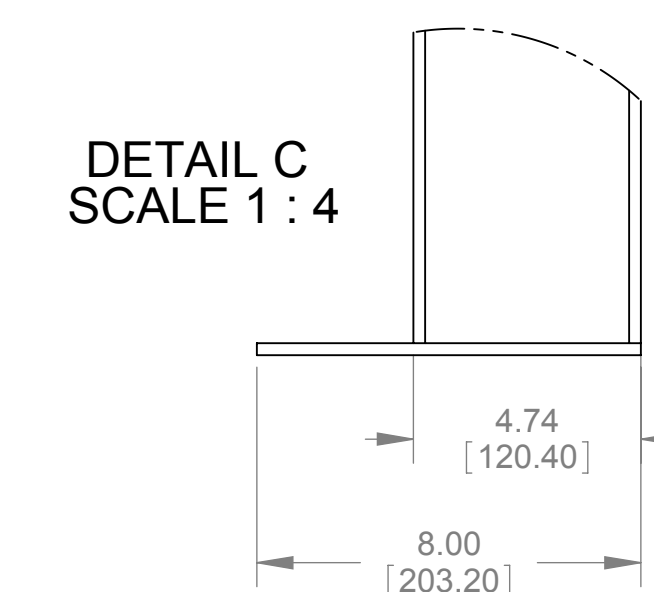

PHONE#: (800)553-5560 (563)587-4401 FAX #: (563)589-2776

FINISH	N/A	MATERIAL	
CONFIDENTIAL	UNLESS OTHERWISE SPECIFIED DIMENSIONS ARE IN INCHES.	DRAWN BY	DAS
THIS DOCUMENT IS THE PROPERTY OF RITE-HITE® DOORS INC. SUBJECT MATTER HEREIN IS CONFIDENTIAL. DO NOT USE, REPRODUCE, COPY OR DISCLOSE EXCEPT WITH WRITTEN CONSENT OF RITE-HITE® DOORS INC.	TOLERANCES:	DRAWN DATE	MM/DD/YYYY
	X = ±.050	INITIAL ECN	6259
	XX = ±.010	DATE ISSUED	03/01/2001
	XXX = ±.005	REFERENCE	ALL SHEETS ARE THE SAME REVISION STATUS
ANGLE = ±1.0°	THIRD ANGLE PROJECTION	DO NOT SCALE DRAWING	
© 2011 RITE-HITE® DOORS INC.		SIZE MODEL	D 1345
		DWG NO	5281A001
		REV	A
		SCALE	1:24
		PART#	1345A.XXX
		SHEET	1 OF 1