

ROLL-SHIELD™

MANUAL ROLL-UP CURTAIN

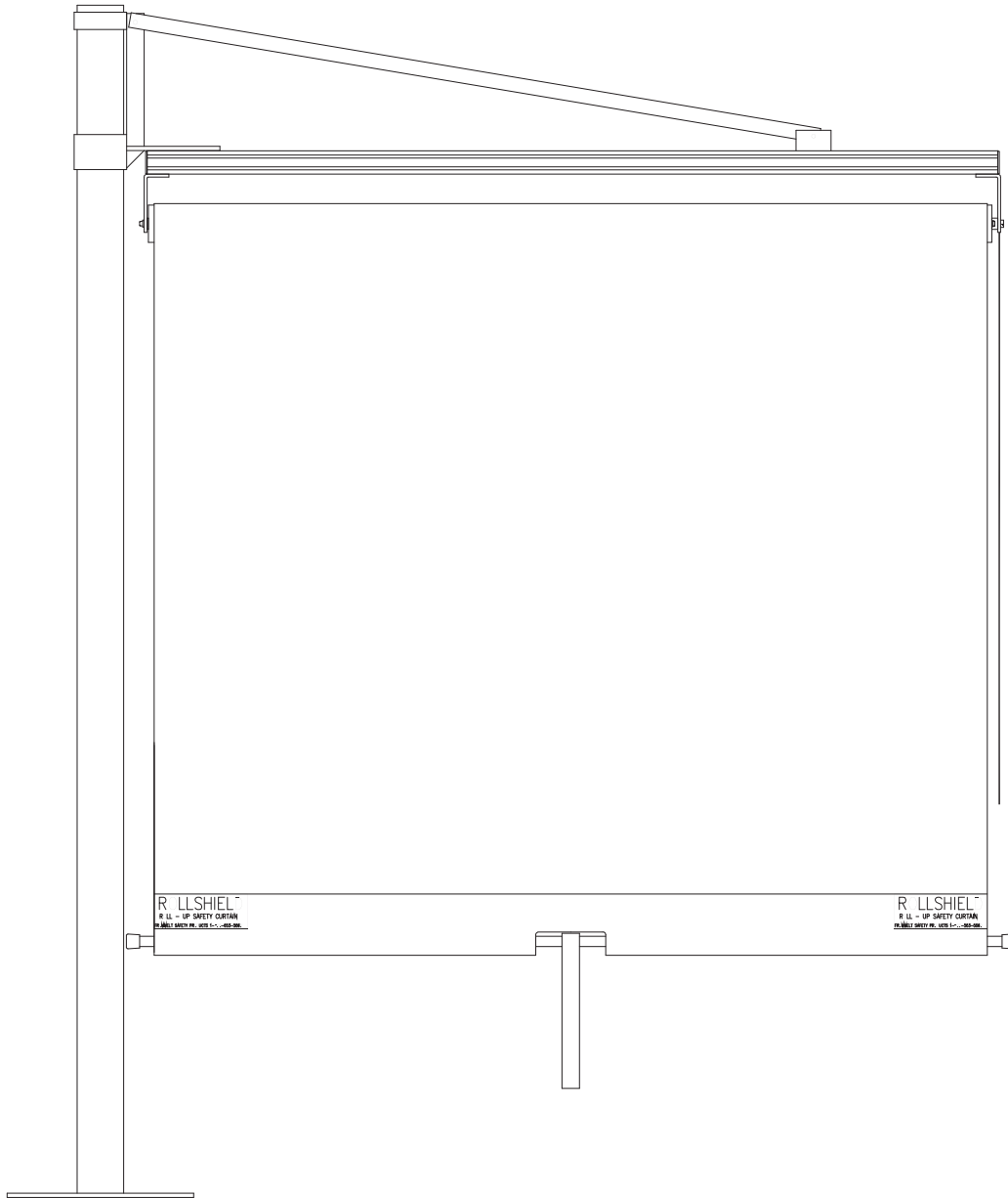

This Manual Covers All Units Shipped to Date.

INTRODUCTION

NOTICE TO USER

Thank you for purchasing the ROLL-SHIELD™ barrier curtain by FROMMELT® SAFETY PRODUCTS.

Our mission is to “Improve Industrial Safety, Security and Productivity Worldwide Through Quality and Innovation.”

If any procedures for the installation, operation or maintenance of the ROLL-SHIELD have been left out of this manual or are not understood, contact Technical Support at 1-563-589-2722.

This versatile curtain rolls quickly into place to prevent the transmission of sparks, heat and fumes, while improving safety and work flow in and around work cells. The spring tension side-to-side design makes it easy to pull into place for effective area protection - and even easier to close for full access. Roll-Shields are a unitized design. Curtains are attached with hook/loop to the spring roller, **Figures 3.1 & 3.2**. The ratchet and spring mechanism is preadjusted accordingly.

WARRANTY

Only Frommelt® Safety Products authorized parts are to be used on this product. Failure to do so may void warranty.

FROMMELT SAFETY PRODUCTS warrants that it's ROLL-SHIELD, will be free from defects in design, materials and workmanship for a period of one (1) year from the date of shipment. It does not cover damage incurred from abuse, misuse or impact. All claims for breach of this warranty must be made within thirty (30) days after the defect is or can, with reasonable care, be discovered. To be entitled to the benefits of this warranty, the products must have been properly installed, maintained, operated within their rated capacities, and not otherwise abused. Periodic lubrication and adjustment is the sole responsibility of the owner. This is FROMMELT SAFETY PRODUCTS exclusive warranty. FROMMELT SAFETY PRODUCTS EXPRESSLY DISCLAIMS ALL IMPLIED WARRANTIES INCLUDING THE IMPLIED WARRANTIES OF MERCHANTABILITY AND FITNESS. Non-standard FROMMELT SAFETY PRODUCTS warranties, if any, must be specified by FROMMELT SAFETY PRODUCTS in writing.

In the event of any defects covered by this warranty, FROMMELT SAFETY PRODUCTS will remedy such defects by repairing or replacing any defective equipment or parts. This shall be the exclusive remedy for all claims whether based on contract negligence or strict liability. Neither FROMMELT SAFETY PRODUCTS ANY OTHER MANUFACTURER WHOSE PRODUCTS ARE THE SUBJECT OF THIS TRANSACTION, NOR ANY FROMMELT SAFETY PRODUCTS REPRESENTATIVE, SHALL IN ANY EVENT BE LIABLE FOR ANY LOSS OR USE OF ANY EQUIPMENT OR INCIDENTAL OR CONSEQUENTIAL DAMAGES OF ANY KIND WHETHER FOR BREACH OF WARRANTY, NEGLIGENCE, OR STRICT LIABILITY. The application of a manufacturer's specifications to a particular job is the responsibility of the purchaser.

FROMMELT SAFETY PRODUCTS

4343 Chavenelle Drive
 P.O. Box 1200
 Dubuque, Iowa 52002-2654
 Toll Free Sales: 800-553-5560
 Sales: 563-589-4401
 Sales Fax: 563-589-2776
 Service: 563-589-2722
 Service Fax: 563-589-2737
 www.frommeltsafety.com

CURTAIN REPLACEMENT

1. To replace curtain and adjust spring tension, **Figure 5.2** shows industrial ratchet assembly.
2. Roll existing curtain down until hook/loop attachment can be seen. Make sure curtain is locked down before releasing pressure.
3. Pull curtain away from hook attachment on spring roller.
4. Attach new curtain to spring roller using hook/loop fastener attachment. Give curtain a light tug and roll up curtain. If spring tension was lost, remove curtain.
5. Observing **Figure 5.2**, wind metal roller in the direction that allows the latches to catch. Recommended pretension is 10-14 revolutions depending on curtain height and weight.
6. Attach curtain to metal roller and attempt to roll up with a light tug. If curtain rolls up part way and stops, more spring tension is required. Remove curtain and wind spring roller additional turns. If curtain goes up too quickly, too much pretension has been applied. Carefully remove a couple revolutions of pretension. Repeat procedure until desired roll up speed is reached.

TROUBLESHOOTING

1. Curtain pulls too hard, too much tension on roller, remove tension per Curtain Replacement.
2. Binding of curtain, adjust curtain position to eliminate binding.
3. Curtain pulls too fast, too much tension on roller, remove tension per Curtain Replacement.
4. Curtain pulls too easy, not enough tension on roller, add tension per Curtain Replacement.
5. Curtain does not roll up without catching, not enough tension on roller, add tension per Curtain Replacement.
6. Curtain does not have latching position, spring drive installed upside down, rotate spring drive 180°.
7. Curtain over rolls, bottom tubing out of position, center tubing on curtain.

 **WARNING!!!**

If the curtain becomes separated from the spring roller, refer to the Section CURTAIN REPLACEMENT.

 **CAUTION !!!**

If mounting to a wall, DO NOT lag, through bolt only. Use minimum 3/8"Ø threaded rod or grade 5 bolts.

 **CAUTION !!!**

DO NOT secure support post to concrete less than 4" in depth. DO NOT use lags under 3/8"Ø.

INSTALLATION

STANDARD MODELS

All standard Roll-Shields are a unitized design. Curtains are attached with velcro and wrapped around the metal roller shown in **Figure 3.1**. The ratchet and spring mechanism are preadjusted accordingly

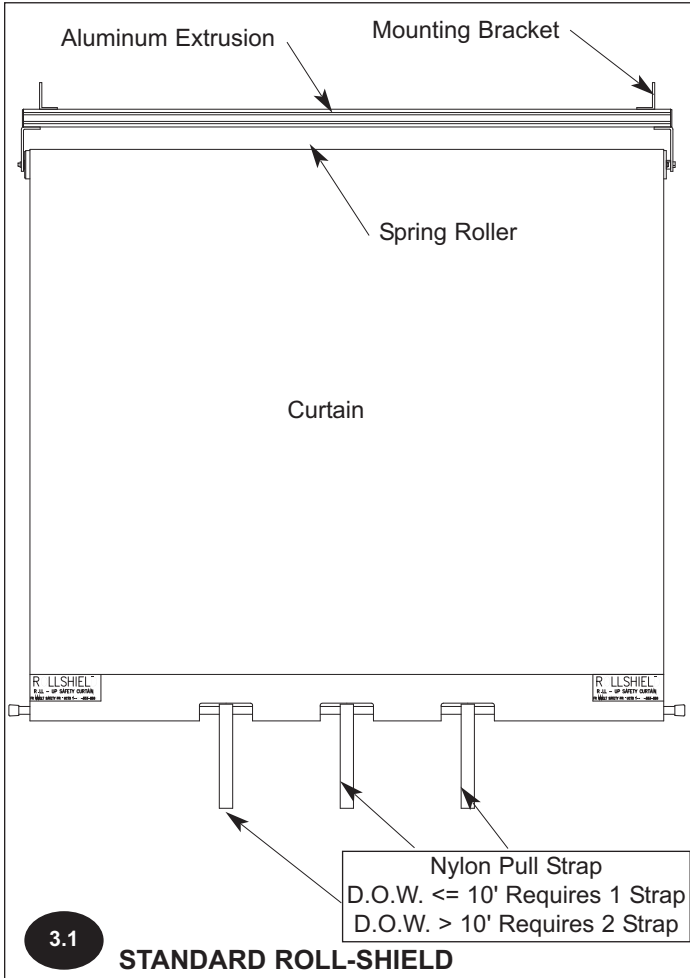

! CAUTION !!!
Curtain is under constant spring tension. Hold secure when opening and closing.

! CAUTION !!!
DO NOT allow weight of unit to rest on bottom bracket before fastening to the top bracket.

SWIVEL HEAD MODEL

Assembly is required for swivel mount Roll-Shields.

1. Remove all contents from containers.
2. Familiarize yourself with all parts shown in **Figure 3.2**.
3. Bolt swivel head to the aluminum extrusion using four 5/16-18 x 3" HHCS that are provided. Make sure swivel head is on top of aluminum extrusion.
4. Secure support arm to swivel head using 5/16" x 3/4" bolt and lock nut.
5. Support arm is secured to U-bracket with 5/16" x 3 1/2" bolt with two spacers and lock nut.
6. Note, swivel strap on **Figure 5.3**.

Installation

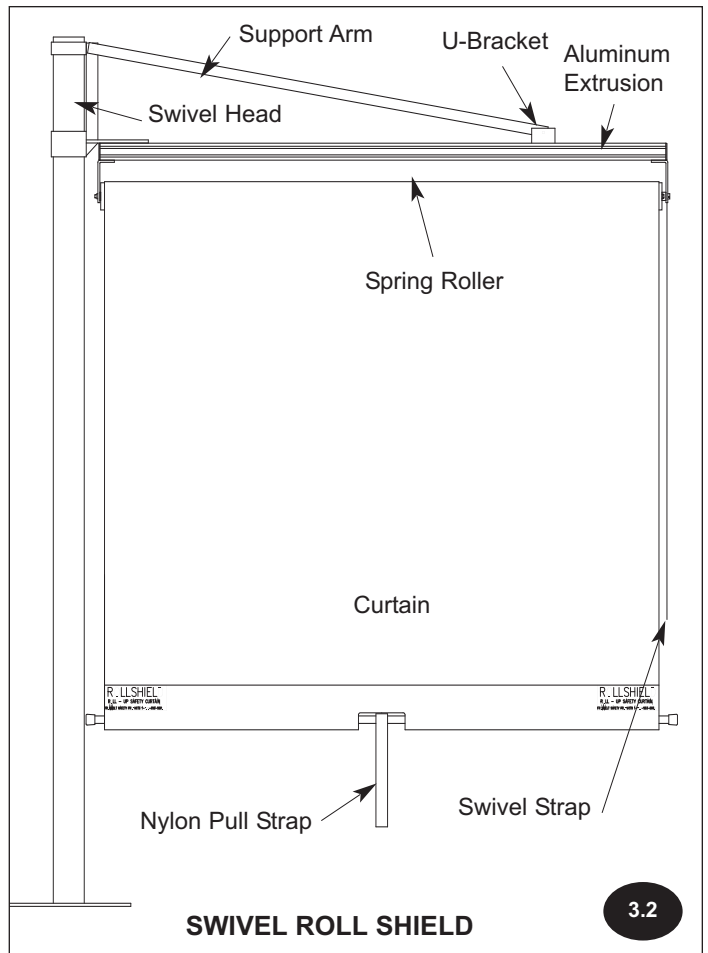

ASSEMBLY

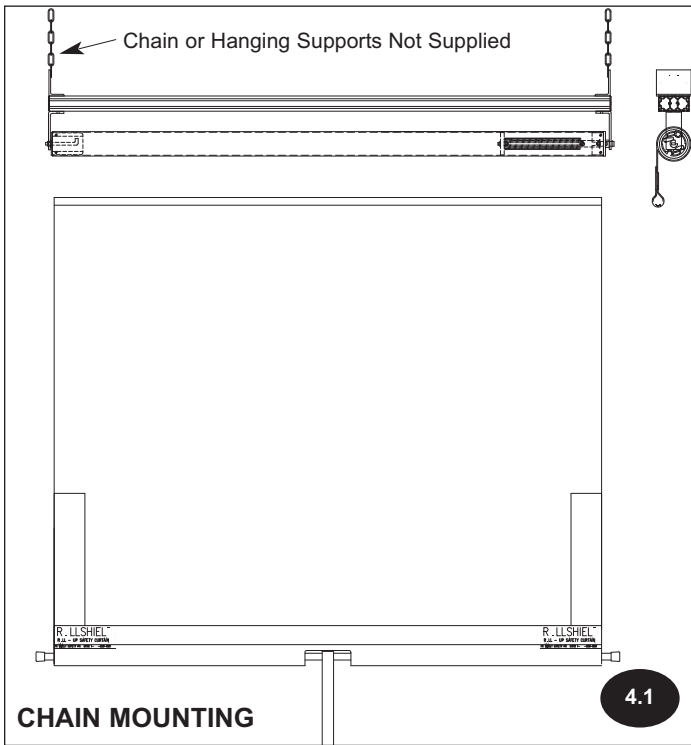

INSTALLATION CHAIN MOUNTED

Standard Roll-Shield units are equipped for chain mounting. **Figure 4.1** illustrates a typical chain mounted Roll-Shield.

1. Attach chain to a beam or other structurally sound object using beam clamps or bolts.
2. Fasten chain to angle brackets on top of aluminum extrusion using 1/4" x 1" bolt, two washers and a lock nut.
3. Tighten all fasteners.

Minimum requirements:

Chain - 3/16" nominal diameter, NACM grade 28

Bolts - 5/16" nominal diameter, SAE grade 5

FLOOR MOUNTED

1. Mark concrete floor for 12" bolt centers.
2. Drill concrete floor and install drop-in anchors or stud anchors.
3. Stand floor pedestal upright and secure to concrete floor with lags or stud anchor nuts, **Figure 4.2**.

Minimum requirements:

Pole - 4" O.D., 1/4" wall, Electric Weld, ASTM A 513 HR TYPE 1

Plate - 16" x 16", 3/8" HR

4. Slip height positioning collar onto floor pedestal and field weld at desired height.
5. Liberally apply industrial grease or silicone lubricant to top 10" of floor pedestal.

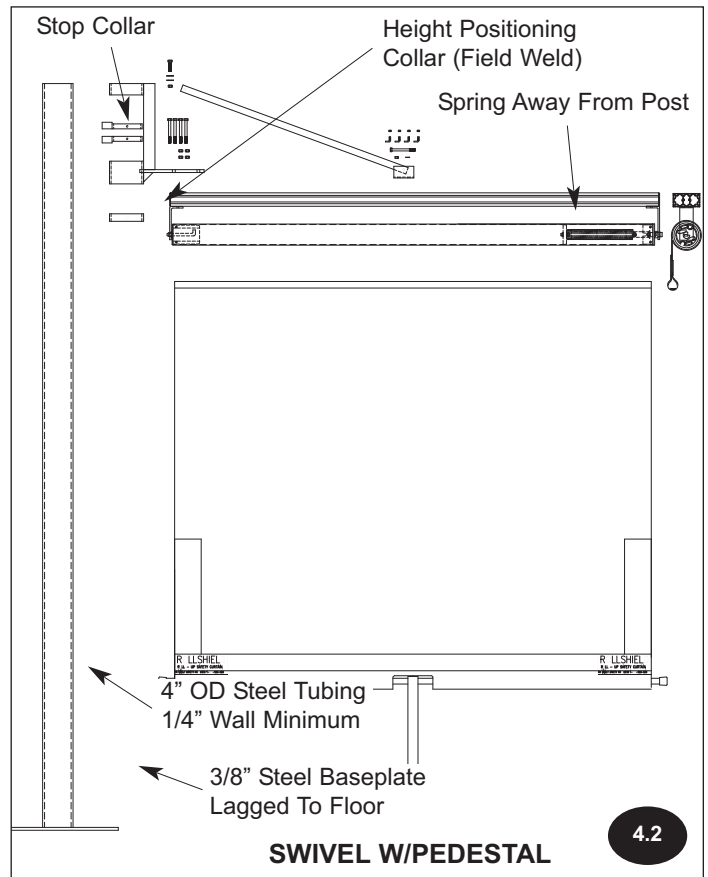

SWIVEL W/PEDESTAL

6. Using a fork truck or similar lifting device, slide swivel head and Roll-Shield assembly onto floor pedestal.
7. Level Roll-Shield assembly by moving U-bracket on aluminum extrusion shown in **Figures 4.2 & 4.3**. Attempt to swivel unit. If unit does not rotate freely, apply more lubricant.

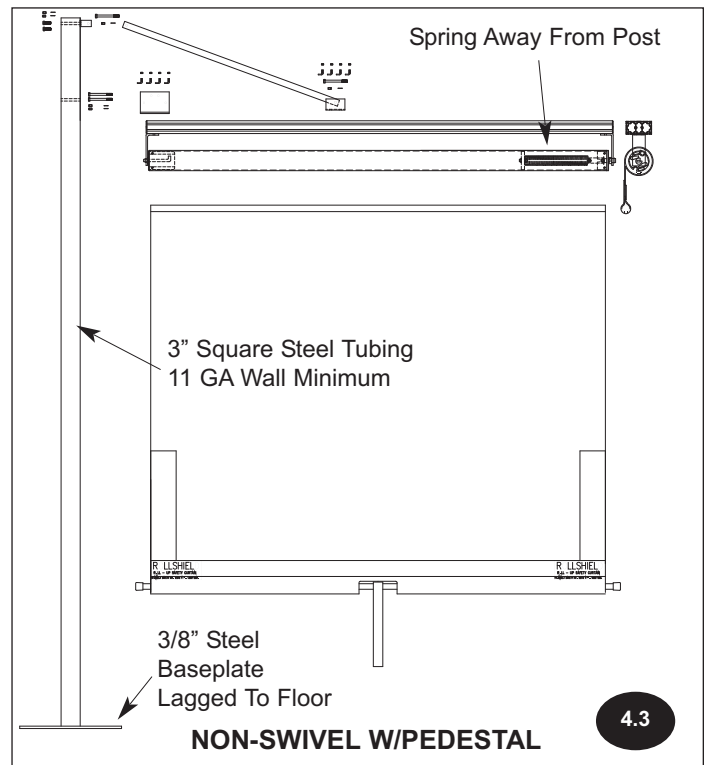

NON-SWIVEL W/PEDESTAL

ASSEMBLY

8. If a swivel stop was purchased (part # SST), slide over top of swivel pedestal. Turn to desired stopping location and tighten set screws. A swivel stop is used to limit the range of motion to avoid colliding with obstructions.

WALL/BEAM MOUNT

1. Mark wall or beam for bolt centers, *Figure 5.1*.
2. Drill 1/2" diameter holes.
3. Secure bottom bracket and liberally apply industrial grease or silicone lubricant to 4" tubing.
4. Using a fork truck or similar lifting device, slide swivel head and Roll Shield assembly onto bottom bracket.
5. Slip swivel stop (if applicable) and top bracket over 4" tubing as shown in *Figure 4.2*. Secure top bracket.
6. Level Roll-Shield assembly using movable U-bracket shown in *Figure 4.2*. Attempt to swivel unit. If unit does not rotate freely, apply more lubricant.

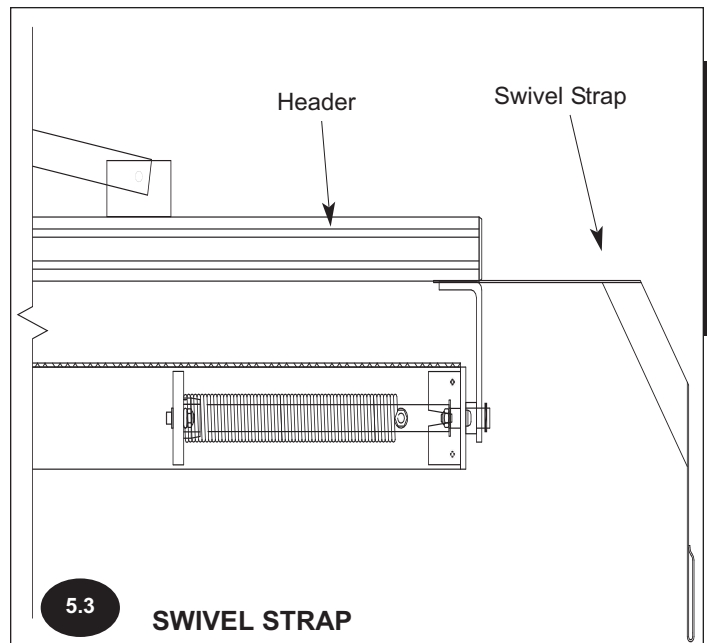
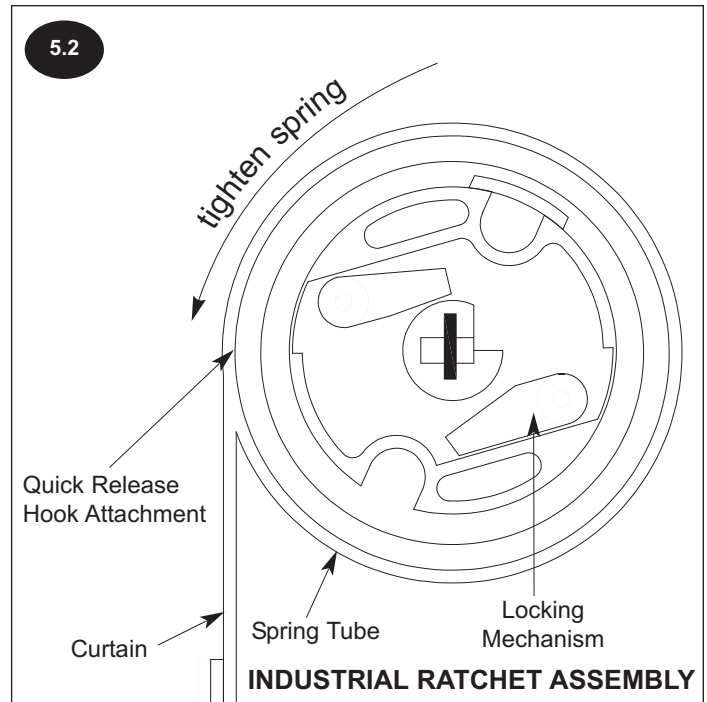
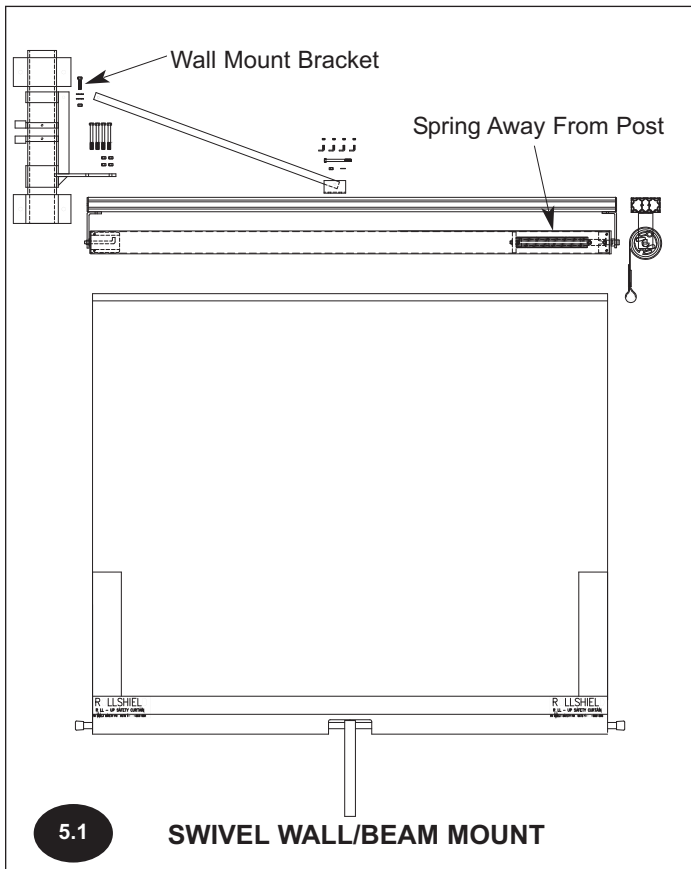

CURTAIN SERVICE PARTS

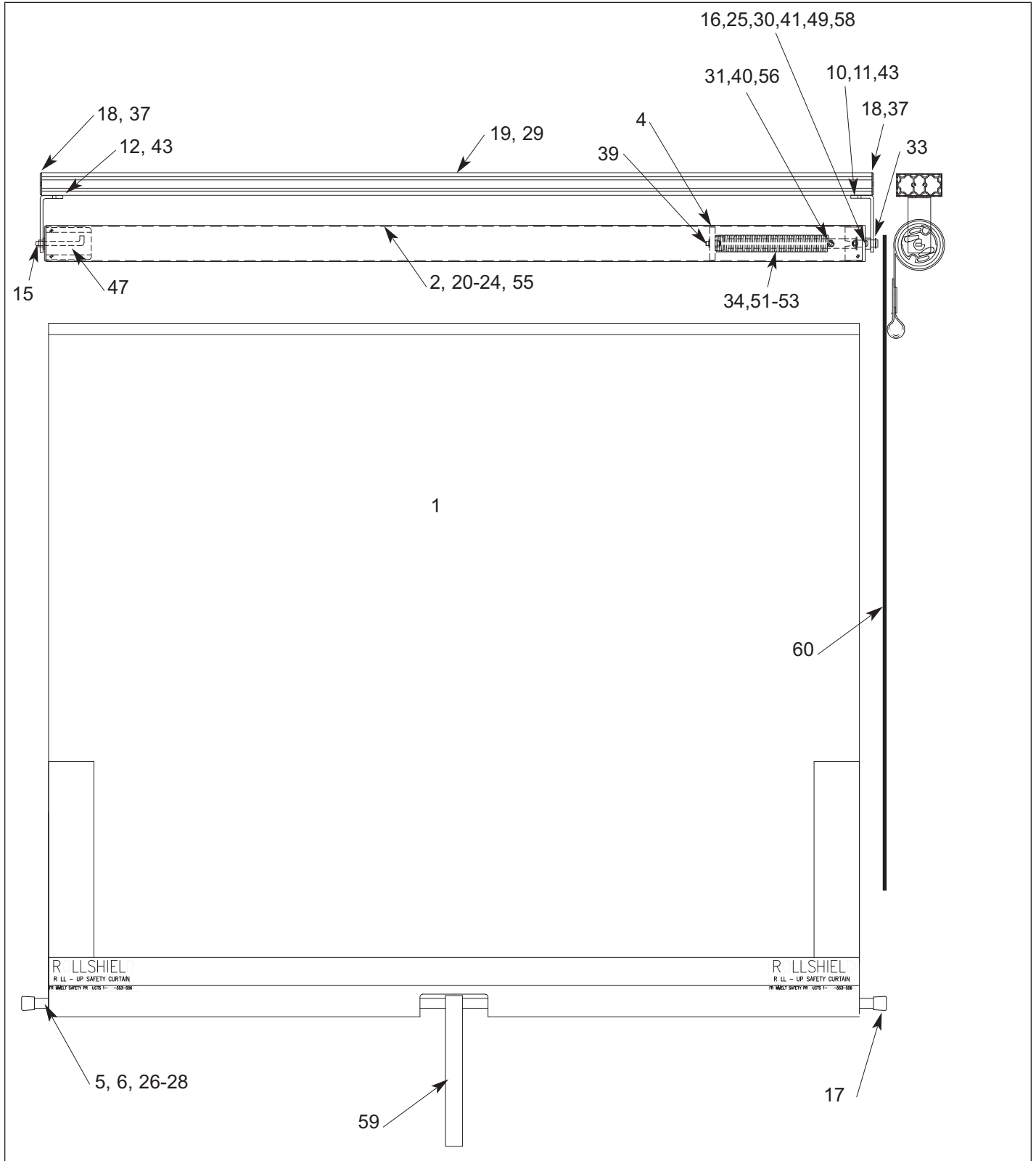

FRAME SERVICE PARTS

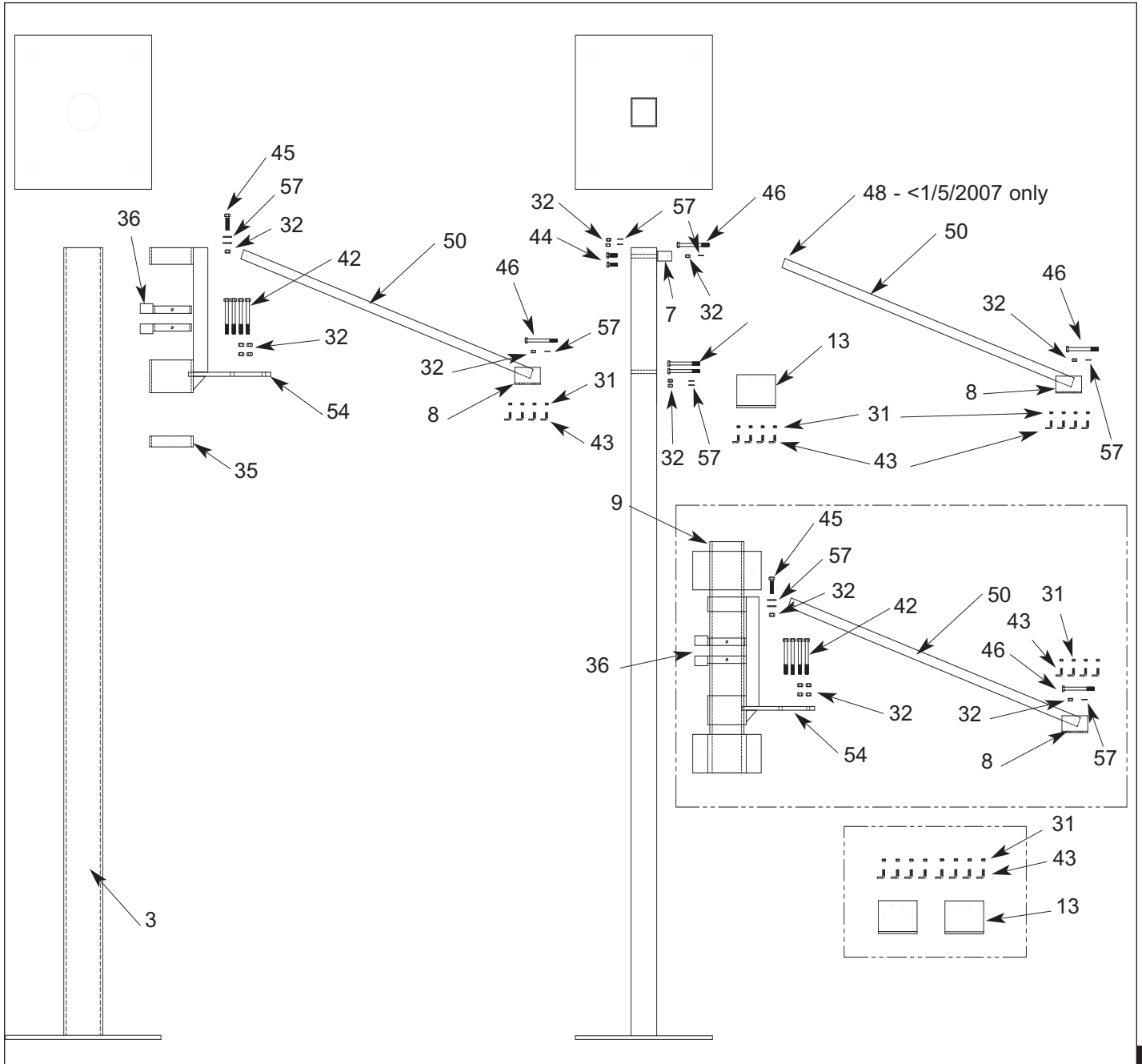

Service Parts

SERVICE PARTS LIST

ITEM	QTY	DESCRIPTION	P/N	ITEM	QTY	DESCRIPTION	P/N
1	1	Curtain Ass'y (d.o.h., d.o.w., Fabric, Vision)	2841....	32	6	Nut, Hex, Nylon, Lock, 5/16-18	55620010
2	1	Roller Ass'y, RS, w/Spring	6740....	33	1	Cotter Pin, 1/8" x 3/4", znc	64030002
3	1	Support Post (specify swivel/cantilever)	7250....	34	a/r	Shaft, Spring Tube, (specify length)	64400018
4	1	Adapter, Drive, Manual	10300006	35	1	Ring, Swivel Post	67020034
5	1	Curtain Rod, 144"	11150018	36	1/2	Ring, Swivel Stop	67020036
6	1	Curtain Rod, 192"	11150019	37	2/4	Screw, HWH, Self Dr/Tap, #12-14 x 3/4"	67850004
7	1	Bracket, Support, Vertical	14500236	38	4	Screw, PHSMS, Phillips, Tap, #8-18 x 3/4"	67850026
8	1	Bracket, Support, Header	14500536	39	1	Screw, SHCS, 1/4-20 x 1 1/2", GR*, blk	67860005
9	1	Bracket, Weldment, Swivel Head	14500537	40	1	Screw, SHCS, 1/4-20 x 1 1/2", Nylon, patch	67860012
10	1	Bracket, Drive, Slotted, Standard	14500769	41	2	Screw, BHMS, Socket, 1/4-20 x 1 1/4", GR8	67860065
11	1	Bracket, Drive, Slotted, Heavy Duty	14500982	42	4	Bolt, Hex Head, 5/16 x 3", znc	67860070
12	1	Bracket, Non-Drive, Heavy Duty	14500983	43	8/12	Screw, Right Angle, 1/4-20 x 3/4"	67860075
13	2	Bracket, Support (RS)	14501070	44	2	Screw, HHMS, 5/16-18 x 3/4", GR5, znc	67870006
14	1	Bracket, RS, Wall Mount	14500233	45	1	Screw, HHMS, 5/16-18 x 1 3/4", GR5, znc	67870008
15	1	Bushing, UHMW	15552001	46	4	Screw, HHMS, 5/16-18 x 3 1/2", GR5, znc	67870015
16	1	Bushing, 3/4" ID x 7/8" OD x 1/2"	15550029	47	1	Shaft, Stub, 3"	68950069
17	2	Cap, Rubber, 7/8", Blk	16200013	48	2	Spacer (RSS) (<1/5/2007)	70450050
18	2	End Cap, Black ABS	43850061	49	1	Spring, Drive, Manual	70710001
19	a/r	Aluminum Extrusion, T-Slot	44850126	50	1	Support, Arm, Single Stationary, Swivel	71560033
20	1	Roller Extrusion, (8'-4")	44850133	51	1	Spring, .156Ø x 67" Long	71710001
21	1	Roller Extrusion, (10'-4")	44850134	52	1	Spring, .156Ø x 44" Long	71710003
22	1	Roller Extrusion, (12'-4")	44850135	53	1	Spring, .135Ø x 22" Long	71710004
23	1	Roller Extrusion, (15'-4")	44850136	54	1	Support, Pedestal, Wall, w/Brckt, Ptnd	72452023
24	1	Roller Extrusion, (57 3/4")	44850187	55	a/r	Hook Fastener, PSA, 1"	74000024
25	1	Hub, Drive	52940009	56	3	Washer, Flat, 1/4 x 3/4 x 1/16, znc	74110001
26	1	Curtain Rod, 60"	53750035	57	3/6	Washer, Flat, 5/16", znc	74120003
27	1	Curtain Rod, 72"	53750036	58	1	Washer, Flat, 5/8 x 1 3/16 x 3/32, brnz	74160007
28	1	Curtain Rod, 96"	53750037	59	1/2	Nylon Pull Strap (27", Doors >10'D.O.H. =2 straps)	75000013
29	1	Label, Roll-Shield	53850179	60	4.5'	Nylon Swivel Strap (RSS only)	75000013
30	1	Latch, Rolling, RS	54150005	61	1	Entire Unit	3476....
31	8/12	Nut, Lock, 1/4"	55610001				